



09

SCHLAGWERKZEUGE STRIKING TOOLS



HÄMMER UND FÄUSTEL

HAMMERS AND CLUB HAMMERS

SCHLOSSERHÄMMER ENGINEERS HAMMERS

1665-...



Ausführung *Type* deutsche Form, **Köpfe gesenkgeschmiedet**, schwarz lackiert, Arbeitsflächen poliert, Bahnen und Pinne geschliffen, mit Eschenstielen
German pattern, heads die forged, black lacquered, polished faces, peins and faces ground, with ash handles

Normung *Standard* nach **DIN 1041**, Stiele nach **DIN 5111**
according to DIN 1041, shafts according to DIN 5111

Code	ELORA-Nr. ELORA-No.	g	L mm	📦	⚖️ g
1665001007000	1665- 100	100	260	2	145
1665002007000	1665- 200	200	275	2	250
1665003007000	1665- 300	300	300	2	370
1665004007000	1665- 400	400	310	2	460
1665005007000	1665- 500	500	320	2	590
1665006007000	1665- 600	600	325	2	730
1665008007000	1665- 800	800	350	2	910
1665010007000	1665-1000	1000	355	2	1170
1665015007000	1665-1500	1500	380	2	1700
1665020007000	1665-2000	2000	400	2	2285

STIELE FÜR SCHLOSSERHÄMMER HANDLES FOR ENGINEERS HAMMERS

1665ST-...



Ausführung *Type* aus Eschenholz
ash wood

Normung *Standard* **DIN 5111**
DIN 5111

Code	ELORA-Nr. ELORA-No.	g	L mm	📦	⚖️ g
1665001008000	1665ST- 100	100	260	6	50
1665002008000	1665ST- 200	200	275	6	57
1665003008000	1665ST- 300	300	300	6	71
1665004008000	1665ST- 400	400	310	6	100
1665005008000	1665ST- 500	500	320	6	105
1665006008000	1665ST- 600	600	325	6	127
1665008008000	1665ST- 800	800	350	2	149
1665010008000	1665ST-1000	1000	355	2	157
1665015008000	1665ST-1500	1500	380	2	185
1665020008000	1665ST-2000	2000	400	2	285

KEILE FÜR SCHLOSSERHÄMMER WEDGES FOR ENGINEERS HAMMERS

1665KL-...

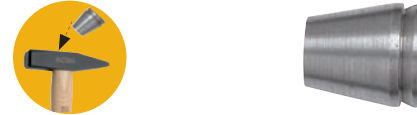

Ausführung *Type* stahlgrau
steel-gray

Code	ELORA-Nr. ELORA-No.	g	Ø mm	📦	⚖️ g
1665401000000	1665KL- 100	100	7	6	1
1665402000000	1665KL- 200	200	8	6	2
1665403000000	1665KL- 300	300	9	6	2
1665404000000	1665KL- 400	400	10	6	3
1665405000000	1665KL- 500	500	12	6	4
1665406000000	1665KL- 600	600	13	6	6
1665408000000	1665KL- 800	800	14	6	7
1665410000000	1665KL-1000	1000	15	6	8
1665415000000	1665KL-1500	1500	15	6	8
1665420000000	1665KL-2000	2000	16	6	11

SCHLOSSERHÄMMER ENGINEERS HAMMERS

1665-K...



↓ Schlagkopf induktiv vergütet
 ↓ Striking head inductive hardened

Ausführung *Type* **Köpfe gesenkgeschmiedet, mit 3-Komponenten Hochsicherheitsstielen**, mechanisch fixiert, Bahnen und Pinne geschliffen, mit angeschmiedeten Sicherheitskragen
heads die forged with 3 component heavy duty safety handles, fixed mechanical, peins and faces ground, with safety forged security collars

Normung *Standard* **DIN 1041**
DIN 1041

Code	ELORA-Nr. ELORA-No.	g	L mm	📦	⚖️ g
1665003007700	1665-K 300	300	304	2	467
1665005007700	1665-K 500	500	325	2	751
1665010007700	1665-K1000	1000	363	2	1372



MODUL-HANDSCHLAGWERKZEUGE **MODULE-HAND STRIKING TOOLS**

OMS-12

9-tlg./pcs.

NEU! NEW!

Schlagköpfe induktiv vergütet!
Striking heads inductive hardened!

Anwendung für Werkzeugwagen *for roller tool cabinet*
Application ELORA-TROLLEY 1215L; ELORA-SUPER-CADDY 1220LOT; ELORA-TOOLJET 1225L
ELORA-TROLLEY 1215L; ELORA-SUPER-CADDY 1220LOT; ELORA-TOOLJET 1225L

Ausführung schwarz, mit gelber Signalfarbe, chemikalienbeständig, Breite: 41,5 cm, Tiefe: 18,9 cm
Type black, with yellow signal colour, chemical resistant, Width: 41,5 cm, Depth: 18,9 cm

Material PE-Hartschaum
Material hard foam insert

Code	ELORA-Nr. ELORA-No.	Inhalt Contents	g
0000411201000	OMS-12	260-200 Flachmeissel Flat Cold Chisel 265-10 Körner Centre Punch 120x4 271KS Splintreiber-Satz Parallel Pin Punch Set 271-150x2; 150x3; 150x4; 150x5; 150x6; 150x8 1665-500 Schlosserhammer Engineers Hammer 500 g	2200
0000411207000	OMS-12L	leeres Modul empty Module	95

MODUL-HANDSCHLAGWERKZEUGE **MODULE-HAND STRIKING TOOLS**

OMS-8

13-tlg./pcs.

NEU! NEW!

Schlagköpfe induktiv vergütet!
Striking heads inductive hardened!

Anwendung für Werkzeugwagen *for roller tool cabinet*
Application ELORA-TROLLEY 1215L; ELORA-SUPER-CADDY 1220LOT; ELORA-TOOLJET 1225L
ELORA-TROLLEY 1215L; ELORA-SUPER-CADDY 1220LOT; ELORA-TOOLJET 1225L

Ausführung schwarz, mit gelber Signalfarbe, chemikalienbeständig, Breite: 41,5 cm, Tiefe: 18,9 cm
Type black, with yellow signal colour, chemical resistant, Width: 41,5 cm, Depth: 18,9 cm

Material PE-Hartschaum
Material hard foam insert

Code	ELORA-Nr. ELORA-No.	Inhalt Contents	g
0000410801000	OMS-8	260-150; -200 Flachmeissel Flat Cold Chisel 262-150 Flachmeissel Flat Cold Chisel 261-150 Kreuzmeissel Cross Cut Chisel 264-120x10x2 Durchtreiber Taper Pin Punches 120x10x3 120x10x4 265-10 Körner Centre Punch 271-3; 4; 5; 6 Splintreiber Parallel Pin Punches 1665-K500 3K-Komponenten Schlosserhammer 3K Engineers Hammer	2200
0000410807000	OMS-8L	leeres Modul empty Module	95

SCHLOSSERHÄMMER **ENGINEERS BALL PEIN HAMMERS**
(INGENIEUR-HÄMMER) **BALL PEIN HAMMERS**

1670-...

Qualitätsholzstiel *quality wooden shaft*
Griffzonenlackierung *grip zone lacquered*

Schlosserhammerkeil *engineers hammer wedge*

Schlagkopf induktiv vergütet
Striking head inductive hardened

Ausführung englische Form, **Köpfe gesen-**
Type **geschmiedet**, schwarz lackiert, *English type, heads die forged, black lacquered, ball peins and Bahnen und Kugelpinne geschliffen, faces ground, with ash handles mit Eschenstielen*

Code	ELORA-Nr. ELORA-No.	g	mm	g
1670100237000	1670- 1/2	1/2	295	310
1670100287000	1670- 3/4	3/4	315	465
1670100347000	1670- 1	1	335	555
1670100387000	1670- 1.1/2	1.1/2	365	825
1670100497000	1670- 2	2	375	1025

STIELE FÜR SCHLOSSERHÄMMER **HANDLES FOR ENGINEERS BALL PEIN HAMMERS**

1670ST-...

Ausführung aus Eschenholz *ash wood*
Type ash wood

Normung DIN 5111 *DIN 5111*
Standard

Code	ELORA-Nr. ELORA-No.	g	mm	g
1670100238000	1670ST-1/2	1/2	295	81
1670100288000	1670ST-3/4	3/4	315	98
1670100348000	1670ST-1	1	335	105
1670100388000	1670ST-1.1/2	1.1/2	365	132
1670100498000	1670ST-2	2	375	150

KEILE FÜR SCHLOSSERHÄMMER **WEDGES FOR ENGINEERS BALL PEIN HAMMERS**

1670KL-...

Ausführung stahlgrau *steel-gray*
Type steel-gray

Code	ELORA-Nr. ELORA-No.	g	mm	g
1670100230000	1670KL-1/2	1/2	8	2
1670400280000	1670KL-3/4	3/4	10	3
1670400340000	1670KL-1	1	12	6
1670400380000	1670KL-1.1/2	1.1/2	13	7
1670400490000	1670KL-2	2	15	8

01
02
03
04
05
06
07
08
09
10
11
12
13

FÄUSTEL ODER SCHLEGEL CLUB HAMMERS

1672-...

Ausführung *Type* deutsche Form, **Köpfe gesenkgeschmiedet**, schwarz lackiert, Arbeitsflächen poliert, Bahnen und Pinne geschliffen, mit Eschenholzstielen *German pattern, heads die forged, black lacquered, polished faces, peins and faces ground, with ash handles*

Normung *Standard* nach **DIN 6475**, Stiele nach **DIN 5135** *according to DIN 6475, shafts according to DIN 5135*

Code	ELORA-Nr. ELORA-No.	g	L mm	Stück	g
1672010007000	1672- 1000	1000	260	2	1180
1672012507000	1672- 1250	1250	260	2	1430
1672015007000	1672- 1500	1500	280	2	1690
1672020007000	1672- 2000	2000	300	2	2200

STIELE FÜR FÄUSTEL HANDLES FOR CLUB HAMMERS

1672ST-...

Ausführung *Type* aus Eschenholz *ash wood*

Normung *Standard* **DIN 5135** *DIN 5135*

Code	ELORA-Nr. ELORA-No.	g	L mm	Stück	g
1672401008000	1672ST-1000	1000	260	6	82
1672412508000	1672ST-1250	1250	260	6	86
1672415008000	1672ST-1500	1500	280	6	115
1672402008000	1672ST-2000	2000	300	6	134

KEILE FÜR FÄUSTEL WEDGES FOR CLUB HAMMERS

1672KL-...

Ausführung *Type* stahlgrau *steel-gray*

Code	ELORA-Nr. ELORA-No.	g	Ø mm	Stück	g
1672410000000	1672KL-1000	1000	14	6	7
1672412500000	1672KL-1250	1250	15	6	8
1672415000000	1672KL-1500	1500	15	6	8
1672420000000	1672KL-2000	2000	16	6	11

FÄUSTEL ODER SCHLEGEL CLUB HAMMERS

1672-K...

Ausführung *Type* **Köpfe gesenkgeschmiedet mit 3-Komponenten Hochsicherheitsstielen**, mechanisch fixiert, mit angeschmiedeten Sicherheitskragen, Bahnen und Pinne geschliffen *heads die forged, with 3 component heavy duty safety handles, fixed mechanical, with safety forged security collars, peins and faces ground*

Normung *Standard* **DIN 6475**, Stiele nach **DIN 5135** *according to DIN 6475, shafts according to DIN 5135*

Code	ELORA-Nr. ELORA-No.	g	L mm	Stück	g
1672008007700	1672-K 800	800	260	2	1031
1672010007700	1672-K1000	1000	260	2	1215
1672012507700	1672-K1250	1250	260	2	1416
1672015007700	1672-K1500	1500	282	2	1816

VORSCHLAGHÄMMER SLEDGE HAMMERS

1673-...

Ausführung *Type* **Köpfe gesenkgeschmiedet**, schwarz lackiert, Arbeitsflächen poliert, Bahnen und Pinne geschliffen, mit Eschenholzstielen *heads die forged, black lacquered, polished faces, peins and faces ground, with ash handles*

Normung *Standard* **DIN 1042** *DIN 1042*

Code	ELORA-Nr. ELORA-No.	g	L mm	Stück	kg
1673030007000	1673- 3000	3000	900	1	3,7
1673040007000	1673- 4000	4000	900	1	4,6
1673050007000	1673- 5000	5000	900	1	5,6
1673060007000	1673- 6000	6000	900	1	6,5
1673080007000	1673- 8000	8000	900	1	8,5
1673100007000	1673-10000	10000	900	1	10,5

STIELE FÜR VORSCHLAGHÄMMER HANDLES FOR SLEDGE HAMMERS

1673ST-...

Ausführung *Type* aus Eschenholz *ash wood*

Code	ELORA-Nr. ELORA-No.	g	L mm	Stück	g
1673430008000	1673ST- 3000	3000	900	2	620
1673440008000	1673ST- 4000	4000	900	2	625
1673450008000	1673ST- 5000	5000	900	2	670
1673460008000	1673ST- 6000	6000	900	2	700
1673480008000	1673ST- 8000	8000	900	2	800
1673410008001	1673ST-10000	10000	900	2	800

ACHTUNG! Stiele für Hämmer sind auch als Ersatzteil in **Hickory-Ausführung** erhältlich. Preise auf Anfrage!

ATTENTION! Lose shafts in **Hickory** are also available. Prices on request!

NEU!
NEU!
NEU!
NEU!

NEU!
NEU!
NEU!
NEU!

KEILE FÜR VORSCHLAGHÄMMER **WEDGES FOR SLEDGE HAMMERS**

1673KL-...



Ausführung *stahlgrau* *steel-gray*
Type

Code	ELORA-Nr. ELORA-No.	g	Ø mm	📁	⚖️ g
1673430008010	1673KL- 3000	3000	20	6	24
1673440008010	1673KL- 4000	4000	20	6	24
1673450008010	1673KL- 5000	5000	20	6	24
1673460008010	1673KL- 6000	6000	20	6	24
1673480008010	1673KL- 8000	8000	20	6	24
1673410008011	1673KL-10000	10000	20	6	24

GIPSBEIL MIT STAHLROHR **GYPSUM HATCHET**

1681



Ausführung *Stiel aus Stahlrohr mit schwarzem Kunststoffhandgriff* *steel tube shaft with black handle*
Type

Code	ELORA-Nr. ELORA-No.	mm	📁	⚖️ g
1681000000000	1681	310	1	800

LATTHAMMER **CARPENTERS HAMMER**

1678



↓ Schlagkopf induktiv vergütet
Striking head inductive hardened

Ausführung *Stiel aus Stahlrohr, mit schwarzem Kunststoffhandgriff* *steel tube shaft with black handle*
Type
Normung **DIN 7239, Form C** *DIN 7239, Form C*
Standard

Code	ELORA-Nr. ELORA-No.	mm	📁	⚖️ g
1678000000000	1678	320	2	600

SCHWEIßER-HAMMER **WELDERS CHIPPING HAMMER**

331



Material *Kopf aus Spezialstahl, Stiel aus ovalem Stahlrohr, geschmiedet* *head made from special steel, oval tubular forged steel handle*
Material

Code	ELORA-Nr. ELORA-No.	mm	📁	⚖️ g
0331000005100	331	290	1	400

SCHONHÄMMER **SOFT FACED HAMMERS**

GUMMIHÄMMER (GUMMI-KOMPOSITIONS-HÄMMER) **RUBBER MALLETS**

1620-...

Achtung: *Gummihammerköpfe sind als Ersatzteil auf Anfrage verfügbar!*
Attention: Rubber mallet heads are available on request!



Ausführung *mit zwei flachen Bahnen, mit Eschenholzstielen* *with two flat faces, ash handles*
Type
Normung **DIN 5128, Form A, Shore D=90** *DIN 5128, Form A, Shore D=90*
Standard

Code	ELORA-Nr. ELORA-No.	Kopf-Ø mm Head-Ø mm	Kopf-Länge mm Head-length mm	mm	📁	⚖️ g
1620000557000	1620- 55	55	90	320	2	350
1620000657000	1620- 65	65	115	340	2	520
1620000757000	1620- 75	75	130	380	2	750
1620000907000	1620- 90	90	140	380	2	1130

KLAUENHÄMMER **CLAW HAMMERS**

1680-...



↓ Schlagkopf induktiv vergütet
Striking head inductive hardened

Ausführung *amerikanisches Modell, Stiele aus Stahlrohr, mit schwarzen Kunststoffhandgriffen, Bahnen und Klauen poliert* *American pattern, steel tube shafts with black handles, peins and claws polished*
Type

Code	ELORA-Nr. ELORA-No.	Bahn-Ø mm Face-Ø mm	mm	📁	⚖️ g
1680000000000	1680-330	28	330	2	765
1680000010000	1680-450	28	450	2	850

01
02
03
04
05
06
07
08
09
10
11
12
13

**KUNSTSTOFF- ODER TREIB-
HAMMER (AUSBEULHÄMMER)
AUS „CELLULOSE-ACETAT“** **SOFT FACED
HAMMERS,
“CELLULOSE-ACETATE”**

1660-...



Montage/ Assembly

Ausführung *Type* Zinkguss-Mittelteile mit **Führungs- und Schutzhülsen** für die Stiele, **Schlagköpfe** auswechselbar, ergonomische **Eschenstiele** *centric encasements made from cast zinc, with **bushing and protection sleeves, replaceable striking faces, ergonomic ash shafts***

Material *Material* Schlagköpfe aus Cellulose-Acetat, Stiele aus Eschenholz *striking faces made from Cellulose Acetate, ash handles*

Normung *Standard* **DIN 53505, Shore D=65** *DIN 53505, Shore D=65*

Code	ELORA-Nr. ELORA-No.	Kopf-Ø mm Head-Ø mm	L mm	📦	⚖️ g
1660000220000	1660- 22	22	250	2	145
1660000270000	1660- 27	27	265	2	230
1660000320000	1660- 32	32	280	2	310
1660000350000	1660- 35	35	290	2	405
1660000400000	1660- 40	40	320	2	570
1660000500000	1660- 50	50	340	2	845
1660000600000	1660- 60	60	340	2	1345

**ERSATZ-SCHLAGKÖPFE
„CELLULOSE-ACETAT“** **SPARE PLASTIC FACES,
“CELLULOSE-ACETATE”**

1660E-...



Achtung:
Schlagköpfe vor dem Aufschlagen in heißem Wasser erwärmen!
Attention:
Faces have to be warmed up in hot water before assembling!

Anwendung *Application* Ersatzteile für Kunststoff-, Treib- und Ausbeulhammer *spare parts for faced hammers*

Ausführung *Type* verschleiß- und bruchfestes Material *abrasion proofed and break resistant material*

Material *Material* Cellulose Acetat *Cellulose Acetate*

Code	ELORA-Nr. ELORA-No.	Kopf-Ø mm Head-Ø mm	📦	⚖️ g
1660010220000	1660E- 22	22	6	6
1660010270000	1660E- 27	27	6	14
1660010320000	1660E- 32	32	6	22
1660010350000	1660E- 35	35	6	28
1660010400000	1660E- 40	40	6	35
1660010500000	1660E- 50	50	6	68
1660010600000	1660E- 60	60	6	106

ACHTUNG!
Verbrauchte Köpfe für ELORA-Nr. 1660 und ELORA-Nr 1661, **durch kräftiges Linksdrehen entfernen**. Neue Köpfe ohne Drehen, durch **“Schlag oder Druck”** auftreiben!

ATTENTION!
Used striking heads for ELORA-No. 1660 and ELORA-No. 1661, **have to be removed through a powerful turn**. New striking heads have to be fixed **through a strike at the hammer!**

**STIELE FÜR KUNSTSTOFF-,
TREIB- UND AUSBEULHÄMMER** **HANDLES FOR SOFT
FACED HAMMERS**

1660ST-...



Ausführung *Type* aus Eschenholz *ash wood*

Code	ELORA-Nr. ELORA-No.	Ø mm	L mm	📦	⚖️ g
1660400228000	1660ST-22	22	250	6	44
1660400278000	1660ST-27	27	265	6	51
1660400328000	1660ST-32	32	280	6	55
1660400358000	1660ST-35	35	290	6	58
1660400408000	1660ST-40	40	320	6	82
1660400508000	1660ST-50	50	340	6	90
1660400608000	1660ST-60	60	340	6	100

ACHTUNG! **ATTENTION!**
Stiele für Hämmer sind auch als Ersatz- *Lose shafts in Hickory are also* teil in **Hickory-Ausführung** erhältlich. *available. Prices on request!*
Preise auf Anfrage!

**KEILE FÜR KUNSTSTOFF-,
TREIB- UND AUSBEULHÄMMER** **WEDGES FOR SOFT
FACED HAMMERS**

1660KL-...

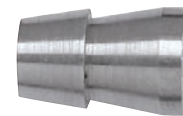

Ausführung *Type* stahlgrau *steel-gray*

Code	ELORA-Nr. ELORA-No.	g	Ø mm	📦	⚖️ g
1660410220000	1660KL-22	22	8	6	2
1660410270000	1660KL-27	27	10	6	3
1660410320000	1660KL-32	32	10	6	3
1660410350000	1660KL-35	35	10	6	5
1660410400000	1660KL-40	40	12	6	5
1660410500000	1660KL-50	50	13	6	6
1660410600000	1660KL-60	60	13	6	6

**ELORA-QUALITÄT FÜR
„DURCHSCHLAGENDEN“ ERFOLG!**



**ELORA QUALITY HITS
THE NAIL ON THE HEAD!**

KUNSTSTOFF- ODER TREIB-HÄMMER (AUSBEULHÄMMER) AUS „DESMOPAN“ **SOFT FACED HAMMERS, “DESMOPAN”**



Ausführung Type Zinkguss-Mittelteile mit Führungs- und Schutzhülsen für die Stiele, Schlagköpfe auswechselbar, ergonomische Eschenstiele *centric encasements made from cast zinc, with bushing and protection sleeves, replaceable striking faces, ergonomic ash shafts*

Material Material Schlagköpfe aus Desmopan, Stiel aus Eschenholz *faces made from Desmopan, ash handles*

Normung Standard DIN 53505 Shore D=65 *DIN 53505 Shore D=65*

Code	ELORA-Nr. ELORA-No.	Kopf-Ø mm Head-Ø mm	L mm	📦	⚖️ g
1661000220000	1661- 22	22	250	2	142
1661000320000	1661- 32	32	280	2	330
1661000400000	1661- 40	40	320	2	535
1661000500000	1661- 50	50	335	2	855

ERSATZ-SCHLAGKÖPFE „DESMOPAN“ **SPARE PLASTIC FACES, “DESMOPAN”**



Anwendung Application Ersatzteile für Kunststoff-Treib- und Ausbeulhämmer *spare part for faced hammers*

Ausführung Type verschleiß- und bruchfestes Material *abrasion proofed and break resistant material*

Material Material Desmopan *Desmopan*

Code	ELORA-Nr. ELORA-No.	Kopf-Ø mm Head-Ø mm	📦	⚖️ g
1661010220000	1661E- 22	22	6	14
1661010320000	1661E- 32	32	6	42
1661010400000	1661E- 40	40	6	74
1661010500000	1661E- 50	50	6	130

ACHTUNG! Verbrauchte Köpfe für ELORA-Nr. 1660 und ELORA-Nr 1661, durch kräftiges Linksdrehen entfernen. Neue Köpfe ohne Drehen, durch “Schlag oder Druck” auftreiben!
ATTENTION! Used striking heads for ELORA-No. 1660 and ELORA-No. 1661, have to be removed through a powerful turn. New striking heads have to be fixed through a strike at the hammer!

RÜCKSCHLAGFREIE NYLON-SCHONHÄMMER **“DEAD BLOW” SOFT FACED HAMMERS**

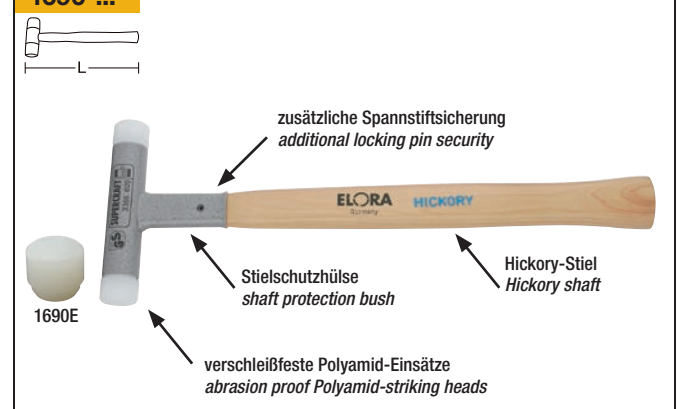

Anwendung Application zum Aufbringen oder Richten von Werkstücken auf Maschinentischen, für rückschlagfreie Schläge ohne Schlagkraftverlust und materialschonendem Arbeiten *to put on or for straighting work-pieces on machine tables for non reboundings and for material protecting works*

Ausführung Type kräftige Stahl-Mittelstücke mit Aufnahmezapfen und Bund zur Aufnahme von Einsätzen. Genau abgestimmte Metallkugeln im Gehäuse (Prinzip der Massenträgheit), Schlagköpfe weiß, auswechselbar, mit ergonomischen Hickory-Stielen *strong steel centre sections with holding pins for the spare nylon faces. The metal balls in the encasement are exact fine tuned for non rebounding (principle of mass inertia), lacquered, replaceable white faces, with ergonomical hickory handles*

Material Material Schlagköpfe aus bestem Nylon, Stiele aus Hickory-Holz *Nylon faces, hickory handles*

Code	ELORA-Nr. ELORA-No.	Kopf-Ø mm Head-Ø mm	L mm	📦	⚖️ g
1690000206000	1690- 20	20	305	2	230
1690000256000	1690- 25	25	305	2	310
1690000306000	1690- 30	30	330	2	430
1690000356000	1690- 35	35	330	2	550
1690000406000	1690- 40	40	350	2	720
1690000456000	1690- 45	45	365	2	850
1690000506000	1690- 50	50	360	1	1030
1690000606000	1690- 60	60	360	1	1750
1690000706000	1690- 70	70	380	1	2290
1690000806000	1690- 80	80	380	1	3200

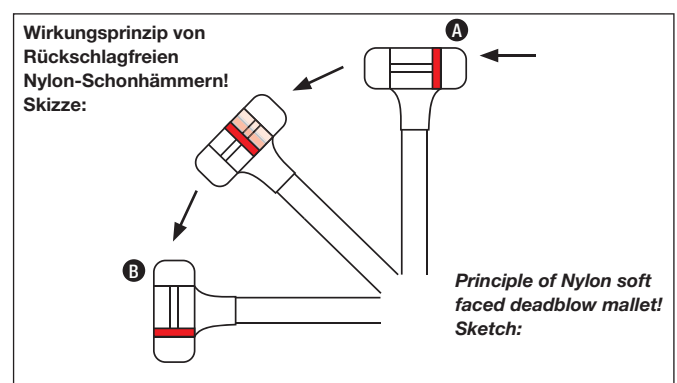

A Gewichtsverlagerung beim Schlagen nach hinten *weight is shifted to the back on start of stroke*

B Gewichtsverlagerung beim Aufschlag nach vorne, somit wird dem Rückprall entgegen gewirkt *weight is shifted to front on impact, which also counteracts rebound*

01
02
03
04
05
06
07
08
09
10
11
12
13

ERSATZ-SCHLAGKÖPFE „NYLON“ SPARE NYLON FACES “DEAD BLOW”

1690E-...



Anwendung / Application: Ersatzteile für rückschlagfreie Nylon-Schonhämmer / spare parts for nylon “Dead Blow” faced Hammers
 Ausführung / Type: verschleiß- und bruchfestes Material / abrasion proof and break resistant material
 Material: Polyamid / Polyamid

Code	ELORA-Nr. / ELORA-No.	Kopf-Ø mm / Head-Ø mm		
1690010206000	1690E- 20	20	6	6
1690010256000	1690E- 25	25	6	10
1690010306000	1690E- 30	30	6	18
1690010356000	1690E- 35	35	6	24
1690010406000	1690E- 40	40	6	32
1690010456000	1690E- 45	45	6	40
1690010506000	1690E- 50	50	2	55
1690010606000	1690E- 60	60	2	95
1690010706000	1690E- 70	70	2	130
1690010806000	1690E- 80	80	2	200

ACHTUNG!

Verbrauchte Köpfe für ELORA-Nr. 1660 und ELORA-Nr 1661, **durch kräftiges Linksdrehen entfernen**. Neue Köpfe ohne Drehen, **durch “Schlag oder Druck” auftreiben!**

ATTENTION!

Used striking heads for ELORA-No. 1660 and ELORA-No. 1661, **have to be removed through a powerful turn**. New striking heads **have to be fixed through a strike at the hammer!**

SIMPLEX-SCHONHÄMMER SIMPLEX SOFT FACED HAMMERS

1685-...

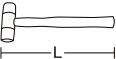

Anwendung / Application: nur zu verwenden mit Schlagköpfen ELORA-Nr. 1687E für variable Einsatzarten (Schlagköpfe sind im Preis nicht enthalten) / only for use with striking faces of ELORA-No.1687E for variable applications (striking faces are not included in price)
 Ausführung / Type: 2-teilige Spanngehäuse aus Tempereguss mit kräftigen Rillenprofilen und austauschbaren Einsätzen, Stiele aus Hartholz / two-part encasements made from malleable cast iron with strong groove profiles and changeable striking head spare parts, handles made from deciduous wood
 Material: Grundgehäuse aus Tempereguss, Stiele aus Hartholz / malleable cast iron housing, shafts of deciduous wood

Code	ELORA-Nr. / ELORA-No.	Schlagkopfaufnahme Ø mm / for faces Ø mm	L mm		
1685000306000	1685- 30	30	300	2	380
1685000406000	1685- 40	40	330	2	720
1685000506000	1685- 50	50	370	2	890
1685000606000	1685- 60	60	405	1	1150
1685000806000	1685- 80	80	495	1	2210

SIMPLEX-SCHONHÄMMER SIMPLEX SOFT FACED HAMMERS

1686-...



Anwendung / Application: nur zu verwenden mit Schlagköpfen ELORA-Nr. 1687E für variable Einsatzarten (Schlagköpfe sind im Preis nicht enthalten) / only for use with striking faces of ELORA-No.1687E for variable applications (striking faces are not included in price)
 Ausführung / Type: 2-teilige Spanngehäuse aus Tempereguss mit kräftigen Rillenprofilen und austauschbaren Einsätzen, Stiele aus Hartholz / two-part encasements made from malleable cast iron with strong groove profiles and changeable striking head spare parts, handles made from deciduous wood
 Material: Grundgehäuse aus Leichtmetall, Stiele aus Hartholz / light alloy housing, shafts of deciduous wood

Code	ELORA-Nr. / ELORA-No.	Schlagkopfaufnahme Ø mm / for faces Ø mm	L mm		
1686000306000	1686- 30	30	300	2	205
1686000406000	1686- 40	40	350	2	375
1686000506000	1686- 50	50	370	2	450
1686000606000	1686- 60	60	405	1	555

SIMPLEX-SCHONHAMMER KOPF SKIZZE SIMPLEX SOFT FACED HAMMER HEAD SKETCH

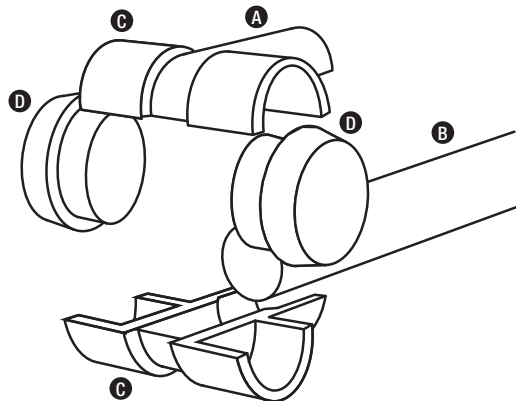

- A** Stahl-Spannschraube / steel clamping screw
- B** Stiel geschweift / shaft
- C** Guss-Spanngehäuse (2-tlg.) mit kräftigem Rillenprofil / two-part encasement with strong groove profile
- D** austauschbare Einsätze / changeable striking heads

ACHTUNG!

Simplex-Schonhammergehäuse- und Stiele sind als Ersatzteile verfügbar. Preise auf Anfrage!

ATTENTION!

All spare parts of “Simplex” Soft Faced Hammers like for e.g. diecast housings or shafts are available from ELORA. Price on request!

SCHLAGKÖPFE FÜR "SIMPLEX"-SCHONHÄMMER

STRIKING FACES FOR "SIMPLEX" SOFT FACED HAMMERS

1687E-...



Anwendung zu verwenden mit Simplex-Schonhämmern
Application ELORA-Nr. 1685 und 1686
Ausführung siehe Tabelle
Type
Material siehe Tabelle
Material

for use with "SIMPLEX" Soft Faced Hammers
ELORA-No. 1685 and 1686
see below
see below

Code	ELORA-Nr. ELORA-No.	Kopf Head Ø mm	Material	Farbe Colour	Schlag- arten Striking type	📦	⚖️ g
1687010306000	1687E- TPS 30	30	TPE-soft TPE-soft	blau blue	weicher Schlag soft strike	6	24
1687010406000	1687E- TPS 40	40	TPE-soft TPE-soft	blau blue	weicher Schlag soft strike	6	51
1687010506000	1687E- TPS 50	50	TPE-soft TPE-soft	blau blue	weicher Schlag soft strike	2	97
1687010606000	1687E- TPS 60	60	TPE-soft TPE-soft	blau blue	weicher Schlag soft strike	1	150
1687003306000	1687E- GU 30	30	Gummi Rubber	schwarz black	mittelharter Schlag medium strike	6	34
1687003406000	1687E- GU 40	40	Gummi Rubber	schwarz black	mittelharter Schlag medium strike	6	78
1687003506000	1687E- GU 50	50	Gummi Rubber	schwarz black	mittelharter Schlag medium strike	2	130
1687003606000	1687E- GU 60	60	Gummi Rubber	schwarz black	mittelharter Schlag medium strike	1	250
1687003806000	1687E- GU 80	80	Gummi Rubber	schwarz black	mittelharter Schlag medium strike	1	505
1687004306000	1687E- SK 30	30	Gummi Rubber	schwarz black	mittelharter Schlag medium strike	6	22
1687004406000	1687E- SK 40	40	Superkunststoff Special plastic	weiß white	mittelharter Schlag medium strike	6	52
1687004506000	1687E- SK 50	50	Superkunststoff Special plastic	weiß white	mittelharter Schlag medium strike	2	98
1687004606000	1687E- SK 60	60	Superkunststoff Special plastic	weiß white	mittelharter Schlag medium strike	1	160
1687004806000	1687E- SK 80	80	Superkunststoff Special plastic	weiß white	mittelharter Schlag medium strike	1	325
1687011306000	1687E- TPM 30	30	TPE-mid TPE-mid	grau grey	mittelharter Schlag medium strike	6	24

Code	ELORA-Nr. ELORA-No.	Kopf Head Ø mm	Material	Farbe Colour	Schlag- arten Striking type	📦	⚖️ g
1687011406000	1687E- TPM 40	40	TPE-mid TPE-mid	grau grey	mittelharter Schlag medium strike	6	51
1687011506000	1687E- TPM 50	50	TPE-mid TPE-mid	grau grey	mittelharter Schlag medium strike	2	97
1687011606000	1687E- TPM 60	60	TPE-mid TPE-mid	grau grey	mittelharter Schlag medium strike	1	140
1687006306000	1687E- KU 30	30	Kunststoff Plastic	rot red	harter Schlag hard strike	6	26
1687006406000	1687E- KU 40	40	Kunststoff Plastic	rot red	harter Schlag hard strike	6	58
1687006506000	1687E- KU 50	50	Kunststoff Plastic	rot red	harter Schlag hard strike	2	116
1687006606000	1687E- KU 60	60	Kunststoff Plastic	rot red	harter Schlag hard strike	1	180
1687008306000	1687E- NY 30	30	Nylon Nylon	weiß white	härtester Schlag hardest strike	6	28
1687008406000	1687E- NY 40	40	Nylon Nylon	weiß white	härtester Schlag hardest strike	6	64
1687008506000	1687E- NY 50	50	Nylon Nylon	weiß white	härtester Schlag hardest strike	2	120
1687008606000	1687E- NY 60	60	Nylon Nylon	weiß white	härtester Schlag hardest strike	1	200
1687008806000	1687E- NY 80	80	Nylon Nylon	weiß white	härtester Schlag hardest strike	1	405
1687009306000	1687E- WM 30	30	Weichmetall Soft metal	silber silver	höchste Schlagwucht top impact	6	50
1687009406000	1687E- WM 40	40	Weichmetall Soft metal	silber silver	höchste Schlagwucht top impact	6	122
1687009506000	1687E- WM 50	50	Weichmetall Soft metal	silber silver	höchste Schlagwucht top impact	2	250
1687009606000	1687E- WM 60	60	Weichmetall Soft metal	silber silver	höchste Schlagwucht top impact	1	405
1687009806000	1687E- WM 80	80	Weichmetall Soft metal	silber silver	höchste Schlagwucht top impact	1	805

01
02
03
04
05
06
07
08
09
10
11
12
13

HAMMERHALTER HAMMER HOLDERS

1600-...

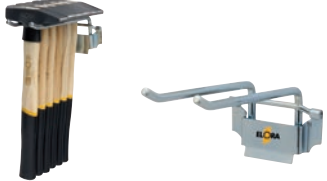

Anwendung für Lochwandpräsentationen von Hämmern *for tool panel presentation of hammers*

Code	ELORA-Nr. ELORA-No.	H mm	📦	⚖️ g
160000017000	1600-1H	200	1	290
160000027000	1600-2H	300	1	365

FÄUSTELHALTER CLUB HAMMER HOLDER

1600-3H



Anwendung für Lochwandpräsentationen von Fäusteln *for tool panel presentation of club hammers*

Code	ELORA-Nr. ELORA-No.	H mm	📦	⚖️ g
160000037000	1600-3H	200	1	445

KFZ-SCHLAGWERKZEUGE AUTOMOTIVE STRIKING TOOLS

SCHLICHT-, SPAN- UND AUSBEULHÄMMER PLANISHING, BUMPING AND DINGING HAMMERS

1601 - 1608



↓ Schlagköpfe induktiv vergütet *Striking heads inductive hardened*

Ausführung geschmiedet, blau lackiert, Arbeitsflächen geschliffen oder kariert *forged, blue lacquered, faces ground or milled*

Material Vergütungsstahl C 45, W.-Nr. 1.0503, Stiele aus Eschenholz *high grade tool steel C 45, Code no. 1.0503, ash handles*

Code	ELORA-Nr. ELORA-No.	Art.-Hinweis Art-Indication	➡				📦	⚖️ g
			∅ mm	H mm	□ mm	H mm		
1601000000000	1601	Doppelter Schlichthammer Planishing hammer	27	105	27	300	1	450
1602000000000	1602		32	105	25	300	1	300
1603000000000	1603		32kariert 32milled	105	25	300	1	300
1604000000000	1604	Spann-, Ausbeul- und Schlichthammer Bumping hammer	40	95	35	310	1	380
1605000000000	1605		40kariert 40milled	95	35	310	1	380
1606000000000	1606		46	115	40	335	1	500
1607000000000	1607		46kariert 46milled	115	40	335	1	500
1608000000000	1608	Ausbeulhammer Dinging hammer	32	165	25	320	1	420

SCHLICHT-, PICK-, TREIB- UND AUSBEULHÄMMER DINGING, PICK, EMBOSING AND BUMPING HAMMERS

1609/1610/1611/1616

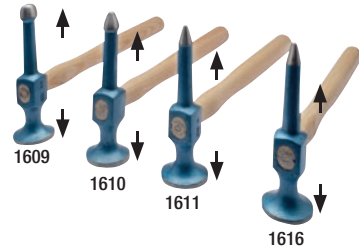

↓ Schlagköpfe induktiv vergütet *Striking heads inductive hardened*

Ausführung geschmiedet, blau lackiert, Arbeitsflächen geschliffen *forged, blue lacquered, faces ground*

Material Vergütungsstahl C45, W.-Nr. 1.0503, Stiele aus Eschenholz *high grade tool steel C45, Code No. 1.0503, ash handles*

Code	ELORA-Nr. ELORA-No.	Art.-Hinweis Art-Indication	➡				📦	⚖️ g
			∅ mm	H mm	∅ mm	H mm		
1609000000000	1609	Schlicht- und Kugelhammer Dinging hammer	40	155	18	300	1	460
1610000000000	1610	Pickhammer, mit Eichelspitze Pick and finishing hammer	40	155	10	300	1	410
1611000000000	1611	Pickhammer, Spezialform Pick Hammer, special shape	40	165	spitz pointed	300	1	440
1616000000000	1616	Tieftreibhammer Embossing hammer	40	165	spitz pointed	400	1	400

PICK- UND AUSBEULHÄMMER PICK AND BUMPING HAMMERS

1612/1615/1618



↓ Schlagköpfe induktiv vergütet *Striking heads inductive hardened*

Ausführung geschmiedet, blau lackiert, Arbeitsflächen geschliffen *forged, blue lacquered, faces grounded*

Material Vergütungsstahl C45, W.-Nr. 1.0503, Stiele aus Eschenholz *high grade tool steel C45, Code No. 1.0503, ash handles*

Code	ELORA-Nr. ELORA-No.	Art.-Hinweis Art-Indication	➡				📦	⚖️ g
			∅ mm	H mm	□ mm	H mm		
1612000000000	1612	Pickhammer mit Pinne Pick hammer	40	160	20 × 3	300	1	450
1615000000000	1615	Doppelter Ausbeulhammer Double bumping hammer	33	160	36 × 10	290	1	500
1618000000000	1618	Ausbeulhammer Bumping hammer	30	115	25 × 5	290	1	300

AUSBEUL- UND GUMMIHÄMMER **BUMPING AND RUBBER HAMMERS**

1613/1614/1619/1620-.../1619E

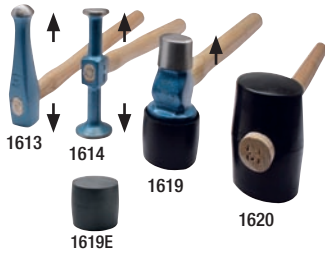

Achtung:
Gummihammerköpfe sind als Ersatzteil auf Anfrage verfügbar!
Attention:
Rubber mallet heads are available on request!

↓ Schlagköpfe induktiv vergütet
Striking heads inductive hardened

Ausführung geschmiedet, blau lackiert, *forged, blue lacquered,*
Type Arbeitsflächen geschliffen *faces ground*
Material Vergütungsstahl C45, *high grade tool steel C45,*
Material W.-Nr. 1.0503, Stiele aus Eschenholz *No. 1.0503, ash handles*

Code	ELORA-Nr. ELORA-No.	Art.-Hinweis Art.-Indication	Abmessungen mm				g
			Ø	—	Ø	—	
1613000000000	1613	Einfacher Ausbeulhammer <i>Fender bumping hammer</i>	28	160	—	330	1 680
1614000000000	1614	Ausbeulhammer <i>Bumping hammer</i>	40	155	30	300	1 430
1619000000000	1619	Ausbeul- und Gummihammer mit auswechselbarem Gummiaufsatz <i>Combination mallet and bumping hammer with replaceable rubber faces</i>	55	140	33	395	1 1000
1619000007000	1619E	Ersatz-Gummikopf für ELORA-Nr. 1619 <i>Spare rubber face for ELORA-No. 1619</i>					1 140
1620000557000	1620- 55	Gummihammer mit zwei	55	90	55	320	2 350
1620000657000	1620- 65	flachen Bahnen nach	65	115	65	340	2 520
1620000757000	1620- 75	DIN 5128, Form A	75	130	75	380	2 750
1620000907000	1620- 90	<i>Rubber mallet acc. to DIN 5128, form A</i>	90	140	90	380	2 1130

HANDAMBOSSE **HAND ANVILS**

1621/1623/1624/1629/1630/1631



Ausführung geschmiedet, blau lackiert, *forged, blue lacquered,*
Type Arbeitsflächen geschliffen *faces ground*
Material Vergütungsstahl C45, *high grade tool steel C45,*
Material W.-Nr. 1.0503 *Code No. 1.0503*

Code	ELORA-Nr. ELORA-No.	Art.-Hinweis Art.-Indication	Abmessungen mm Measurements mm	g
1621000000000	1621	Handamboss für Kotflügelarbeiten <i>General purpose dolly</i>	75 × 63 × 55	1 1200
1623000000000	1623	Generalhandamboss <i>Anvil dolly</i>	62 × 80 × 70 × 100 × 40	1 1400
1624000000000	1624	Generalhandamboss <i>Fender dolly</i>	68 × 54 × 68	1 1200
1629000000000	1629	Handamboss mit Absatzform <i>Heel dolly</i>	80 × 60 × 35	1 1050
1630000000000	1630	Handamboss flach gewölbt <i>Toe dolly</i>	105 × 66	1 950
1631000000000	1631	Handamboss für Kotflügelarbeiten <i>Anvil dolly</i>	74 × 61 × 49	1 1100

HANDAMBOSSE **HAND ANVILS**

1626/1635/1636

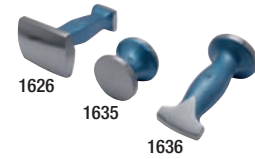

Ausführung geschmiedet, blau lackiert, *forged, blue lacquered,*
Type Arbeitsflächen geschliffen *faces ground*
Material Vergütungsstahl C45, *high grade tool steel C45,*
Material W.-Nr. 1.0503 *Code No. 1.0503*

Code	ELORA-Nr. ELORA-No.	Art.-Hinweis Art.-Indication	Abmessungen mm Measurements mm	g
1626000000000	1626	Großamboss <i>Dome dolly</i>	125 × 85 × 55 × 43 × 33	1 1150
1635000000000	1635	Handamboss mit Diaboloform <i>Diabolo dolly</i>	60 × 0 56 × 0 56	1 750
1636000000000	1636	Rundamboss <i>Round anvil</i>	130 × 48 × 0 58	1 930

HANDFÄUSTE **HAND ANVILS**

1634/1637/1638

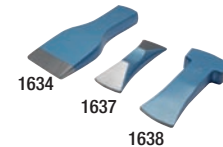

Ausführung geschmiedet, blau lackiert, *forged, blue lacquered,*
Type Arbeitsflächen geschliffen *faces ground*
Material Vergütungsstahl C45, *high grade tool steel C45,*
Material W.-Nr. 1.0503 *Code No. 1.0503*

Code	ELORA-Nr. ELORA-No.	Art.-Hinweis Art.-Indication	Abmessungen mm Measurements mm	g
1634000000000	1634	Meißelform <i>Wedge dolly</i>	192 × 45 × 77	1 1600
1637000000000	1637	leichte Beilform <i>Wedge dolly</i>	118 × 42	1 450
1638000000000	1638	Beilform <i>Wedge dolly</i>	135 × 48 × 46 × 26	1 850

HANDFÄUSTE **HAND ANVILS**

1622/1625/1627/1628/1639



Ausführung geschmiedet, blau lackiert, Arbeitsflächen geschliffen oder kariert *forged, blue lacquered, faces ground or milled*
Material Vergütungsstahl C45, *high grade tool steel C45,*
Material W.-Nr. 1.0503 *Code No. 1.0503*

Code	ELORA-Nr. ELORA-No.	Art.-Hinweis Art.-Indication	Abmessungen mm Measurements mm	g
1622000000000	1622	für Kanten <i>Anvil dolly</i>	130 × 55	1 950
1625000000000	1625	Zehenform <i>Fender dolly</i>	120 × 56 × 21	1 760
1627000000000	1627	für Kotflügelarbeiten <i>Curved dolly</i>	145 × 52	1 550
1628000000000	1628	Keilform <i>Shrinking dolly</i>	112 × 64	1 900
1639000000000	1639	Zehenform, Bahn kariert <i>Grid dolly</i>	125 × 55 × 25	1 1100

01
02
03
04
05
06
07
08
09
10
11
12
13

LÖFFELEISEN BODY SPOONS

1645/1646/1647

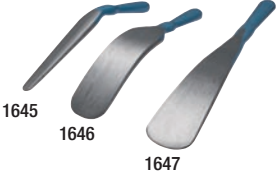

Ausführung geschmiedet, blau lackiert, *forged, blue lacquered,*
 Type Arbeitsflächen geschliffen *faces ground*

Material Vergütungsstahl C 45, *high grade tool steel, C 45,*
 Material W.-Nr. 1.0503 *Code No. 1.0503*

Code	ELORA-Nr. ELORA-No.	Art.-Hinweis Art.-Indication	Abmessungen mm Measurements mm		 g
1645000000000	1645	Löffeleisen, leicht <i>Body spoon, light</i>	270 × 30 × 18	2	550
1646000000000	1646	Löffeleisen, mittel <i>Body spoon, medium</i>	300 × 50	2	850
1647000000000	1647	Löffeleisen, schwer <i>Body spoon, heavy</i>	390 × 25 × 58	2	950

HEBEL-, BIEGE- UND SCHLAGEISEN BODY SPOONS AND BENDING IRONS

1648/1649/1651/1652

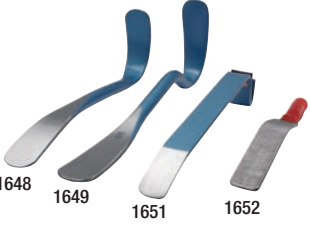

Ausführung geschmiedet, blau lackiert, Arbeits- *forged, blue lacquered,*
 Type flächen geschliffen oder kariert *faces ground or milled*

Material Vergütungsstahl C45, *high grade tool steel C45,*
 Material W.-Nr. 1.0503 *Code No. 1.0503*

Code	ELORA-Nr. ELORA-No.	Art.-Hinweis Art.-Indication	Abmessungen mm Measurements mm		 g
1648000000000	1648	Hebeleisen, leicht <i>Pry/bumping spoon, light</i>	440 × 58 × 150	1	1900
1649000000000	1649	Hebeleisen, schwer <i>Pry/bumping spoon, heavy</i>	500 × 58	1	2200
1651000000000	1651	Biegeisen mit Ledereinsatz <i>Bending iron, leather insert</i>	400 × 25 × 58	2	1000
1652000000000	1652	Schlageisen, Schlagfläche kariert <i>chequered tightening spoon</i>	315 × 40	2	500



BRECHEISEN UND BRECHSTANGEN WRECKING BARS

NAGELEISEN ODER „KUHFRÜSSE“ NAIL-CHISELS OR WRECKING BARS

1675/2-...



NEU! NEW!

Ausführung **Schwere Ausführung** *heavy duty pattern*
 Type

Material C-Mn-Si *C-Mn-Si*

Code	ELORA-Nr. ELORA-No.	mm		 g
1675004001002	1675/2- 400	400	1	1040
1675005001002	1675/2- 500	500	1	1260
1675006001002	1675/2- 600	600	1	1480
1675008001002	1675/2- 800	800	1	1920
1675010001002	1675/2-1000	1000	1	2350

BRECHSTANGEN MIT SPITZEN UND SCHNEIDEN WRECKING BARS WITH POINTS AND EDGES

1676/1-...



NEU! NEW!

Ausführung **Schwere Ausführung** *heavy duty pattern*
 Type

Material C-Mn-Si *C-Mn-Si*

Code	ELORA-Nr. ELORA-No.	mm		 g
1676010001001	1676/1-1000	1000	1	5000
1676012501001	1676/1-1250	1250	1	6500
1676015001001	1676/1-1500	1500	1	8000
1676017501001	1676/1-1750	1750	1	9500
1676020001001	1676/1-2000	2000	1	10500

BRECHSTANGEN MIT SPITZEN UND ABGEWINKELTEN SCHNEIDEN WRECKING BARS WITH POINTS AND BENDED EDGES

1676/2-...



NEU! NEW!

Ausführung **Schwere Ausführung** *heavy duty pattern*
 Type

Material C-Mn-Si *C-Mn-Si*

Code	ELORA-Nr. ELORA-No.	mm		 g
1676010001002	1676/2-1000	1000	1	5000
1676012501002	1676/2-1250	1250	1	6500
1676015001002	1676/2-1500	1500	1	8000
1676017501002	1676/2-1750	1750	1	9500
1676020001002	1676/2-2000	2000	1	10500

BRECHSTANGEN MIT SPITZEN UND KLAUEN **WRECKING BARS WITH POINTS AND CLAWS**

1676/3-...

NEU!
NEW!



Ausführung Type	Schwere Ausführung	heavy duty pattern
Material Material	C-Mn-Si	C-Mn-Si

Code	ELORA-Nr. ELORA-No.	mm		 g
1676010001003	1676/3-1000	1000	1	5000
1676012501003	1676/3-1250	1250	1	6500
1676015001003	1676/3-1500	1500	1	8000
1676017501003	1676/3-1750	1750	1	9500
1676020001003	1673/3-2000	2000	1	10500

BRECHSTANGEN MIT SCHNEIDEN UND KUGELN **WRECKING BARS WITH EDGES AND BALLS**

1676/4-...

NEU!
NEW!



Ausführung Type	Schwere Ausführung	heavy duty pattern
Material Material	C-Mn-Si	C-Mn-Si

Code	ELORA-Nr. ELORA-No.	mm		 g
1676010001004	1676/4-1000	1000	1	5000
1676012501004	1676/4-1250	1250	1	6500
1676015001004	1676/4-1500	1500	1	8000

BRECHSTANGEN MIT KUGELN UND SPITZEN **WRECKING BARS WITH BALLS AND POINTS**

1676/5-...

NEU!
NEW!



Ausführung Type	Schwere Ausführung	heavy duty pattern
Material Material	C-Mn-Si	C-Mn-Si

Code	ELORA-Nr. ELORA-No.	mm		 g
1676010001005	1676/5-1000	1000	1	5000
1676012501005	1676/5-1250	1250	1	6500
1676015001005	1676/5-1500	1500	1	8000

BRECHSTANGEN MIT SPITZEN UND ABGEWINKELTEN SCHNEIDEN **WRECKLING BARS WITH BENEDED EDGES, HEAVY**

1676/6-...

NEU!
NEW!



Ausführung Type	Schwere Ausführung	heavy duty pattern
Material Material	C-Mn-Si	C-Mn-Si

Code	ELORA-Nr. ELORA-No.	mm		 g
1676012501006	1676/6-1250	1250	1	8000
1676015001006	1676/6-1500	1500	1	10000
1676017501006	1676/6-1750	1750	1	12000
1676020001006	1676/6-2000	2000	1	14000

MONTIER- UND HEBELEISEN **MOUNTING BARS**

ROLLKOPFHEBELEISEN **PRY BAR**

164



Anwendung
Application

zum Lösen von Felgen und Rädern, zum Anheben von Zylinderköpfen usw.

for removal of wheel caps and wheels, for lifting cylinder heads etc.

Ausführung
Type

verchromt

chrome plated

Material
Material

Chrom-Vanadium 31 CrV 3, W.-Nr. 1.2208

Chrome-Vanadium 31 CrV 3, Code No. 1.2208

Code	ELORA-Nr. ELORA-No.	mm		 g
0164000000000	164	400	6	475

MONTAGE-HEBELEISEN **MOUNTING BAR**

166



Anwendung
Application

zur Demontage aufeinanderliegender oder verklemmter Teile, zum Zentrieren von Bohrungen zur Durchführung von Schrauben und Bolzen

for dismantling parts being stuck or lying on top of each other, for centering of bore holes for screws and bolts

Ausführung
Type

eine Seite abgewinkelt, andere Seite angespitzt, Vierkantschaft, verchromt

one side offset, other side to end in a point, square shank, chrome plated

Material
Material

Chrom-Vanadium 31 CrV 3, W.-Nr. 1.2208

Chrome-Vanadium 31 CrV 3, Code No. 1.2208

Code	ELORA-Nr. ELORA-No.	mm		 g
0166000000000	166	400	6	500

REIFENMONTIERHEBER **TYRE LEVER**

163



Anwendung
Application

besonders geeignet für schlauchlose Reifen

particular for use on tubeless tyres

Ausführung
Type

verchromt, schwere Ausführung

chrome plated, heavy duty pattern

Material
Material

Chrom-Vanadium 31 CrV 3, W.-Nr. 1.2208

Chrome-Vanadium 31 CrV3, Code-No. 1.2208

Code	ELORA-Nr. ELORA-No.	mm		 g
0163000000000	163	400	6	610

01
02
03
04
05
06
07
08
09
10
11
12
13

REIFENMONTIERHEBER TYRE LEVERS

165-...



Anwendung für PKW und leichte Nutzfahrzeuge
Application for cars and commercial vehicle

Ausführung mit Profilschäften, gerade, gesenkgeschmiedet, verchromt
Type profiled shanks, straight pattern, drop forged, chrome plated

Material Chrom-Vanadium 31 CrV 3, W.-Nr. 1.2208
Material Chrome-Vanadium 31 CrV 3, Code-No. 1.2208

Code	ELORA-Nr. ELORA-No.	L mm	📁	⚖️ g
0165003001000	165-300	300	6	240
0165004001000	165-400	400	6	375
0165005001000	165-500	500	6	610
0165006001000	165-600	600	6	850

REIFENMONTIERHEBER TYRE LEVER

186



Anwendung besonders geeignet für LKW-Reifen
Application especially suitable for use on trucks

Ausführung schwere Ausführung
Type heavy duty pattern

Material Chrom-Vanadium 31 CrV3, W.-Nr. 1.2208
Material Chrome-Vanadium 31 CrV 3, Code-No. 1.2208

Code	ELORA-Nr. ELORA-No.	L mm	📁	⚖️ g
0186000000000	186	600	3	1400

HANDSCHLAGWERKZEUGE HAND STRIKING TOOLS

FLACHMEISSEL FLAT CHISELS

260-...



Schlagkopf induktiv vergütet
Striking head inductive hardened

Anwendung für Metallbearbeitung
Application for metal workings

Ausführung Schäfte flachoval, schwarz lackiert
Type flat oval section shanks, black lacquered

Material Chrom-Vanadium 59 CrV 4, W.-Nr. 1.2242
Material Chrome-Vanadium 59 CrV 4, Code No. 1.2242

Normung DIN 6453
Standard DIN 6453

Code	ELORA-Nr. ELORA-No.	L mm	Schneidbreite l Width of edge mm	Ø mm	📁	⚖️ g
0260001006000	260-100	100	15	14 x 9	5	78
0260001256000	260-125	125	15	14 x 9	5	140
0260001506000	260-150	150	18	17 x 11	5	180
0260001756000	260-175	175	21	20 x 12	5	280
0260002006000	260-200	200	24	23 x 13	5	405
0260002506000	260-250	250	25	23 x 13	5	505
0260003006000	260-300	300	26	23 x 13	5	605
0260004006000	260-400	400	32	26 x 13	5	910

KREUZMEISSEL CAPE CHISELS

261-...



Schlagkopf induktiv vergütet
Striking head inductive hardened

Anwendung für Metallbearbeitung
Application for metal workings

Ausführung Schäfte flachoval, schwarz lackiert
Type flat oval section shanks, black lacquered

Material Chrom-Vanadium 59 CrV 4, W.-Nr. 1.2242
Material Chrome-Vanadium 59 CrV 4, Code No. 1.2242

Normung DIN 6451
Standard DIN 6451

Code	ELORA-Nr. ELORA-No.	L mm	Schneidbreite l Width of edge mm	Ø mm	📁	⚖️ g
0261001506000	261-150	150	6	17 x 11	5	215
0261001756000	261-175	175	7	17 x 11	5	250
0261002006000	261-200	200	8	20 x 12	5	380
0261002506000	261-250	250	9	23 x 13	5	530

FLACHMEISSEL FLAT CHISELS

262-...



Schlagkopf induktiv vergütet
Striking head inductive hardened

Anwendung für Metallbearbeitung
Application for metal workings

Ausführung Schäfte 8-kantig, schwarz lackiert
Type octagon section shanks, black lacquered

Material Chrom-Vanadium 59 CrV 4, W.-Nr. 1.8161
Material Chrome-Vanadium 59 CrV 4, Code No. 1.8161

Code	ELORA-Nr. ELORA-No.	L mm	Schneidbreite l Width of edge mm	Ø mm	📁	⚖️ g
0262001006000	262-100	100	10	8	5	56
0262001256000	262-125	125	12	10	5	68
0262001506000	262-150	150	16	12	5	118
0262001756000	262-175	175	20	14	5	210
0262002006000	262-200	200	22	16	5	310
0262002506000	262-250	250	26	18	5	490
0262003006000	262-300	300	26	18	5	595

KREUZMEISSEL CAPE CHISELS

263-...



Schlagkopf induktiv vergütet
Striking head inductive hardened

Anwendung für Metallbearbeitung
Application for metal workings

Ausführung Schäfte 8-kantig, schwarz lackiert
Type octagon section shanks, black lacquered

Material Chrom-Vanadium 59 CrV 4, W.-Nr. 1.8161
Material Chrome-Vanadium 59 CrV 4, Code No. 1.8161

Code	ELORA-Nr. ELORA-No.	L mm	Schneidbreite l Width of edge mm	Ø mm	📁	⚖️ g
0263001506000	263-150	150	6	12	5	108
0263001756000	263-175	175	8	14	5	180
0263002006000	263-200	200	9	16	5	310
0263002506000	263-250	250	10	18	5	445

NUTENMEISSEL **GROOVING CHISELS**

269-...

→
Schlagkopf induktiv vergütet
Striking head inductive hardened

Anwendung *zum Einarbeiten von Schmiernuten, Maschinenbau* *for oil grooves, machinery construction*
 Ausführung *Schäfte 8-kantig, schwarz lackiert* *octagon section shanks, black lacquered*
 Material *Chrom-Vanadium 58 CrV 4, W.-Nr. 1.8161* *Chrome-Vanadium 58 CrV 4, Code No. 1.8161*
 Normung **DIN 6455** **DIN 6455**

Code	ELORA-Nr. ELORA-No.	L mm	Schneidenbreite mm Width of edge mm	Ø mm	📦	⚖️ g
0269015126020	269- 150×12×2	150	2	12	5	108
0269015126030	269- 150×12×3	150	3	12	5	110
0269015126060	269- 150×12×6	150	6	12	5	118

SPITZMEISSEL **POINT CHISELS**

364-...

→
Schlagkopf induktiv vergütet
Striking head inductive hardened

Anwendung *für Steinbearbeitung* *for use on masonry*
 Ausführung *Schäfte 8-kantig, schwarz lackiert* *octagon section shanks, black lacquered*
 Material *Chrom-Vanadium 58 CrV 4, W.-Nr. 1.8161* *Chrome-Vanadium 58 CrV 4, Code No. 1.8161*
 Normung **DIN 7256** **DIN 7256**

Code	ELORA-Nr. ELORA-No.	L mm	Schneidenbreite mm Width of tip mm	Ø mm	📦	⚖️ g
0364002006000	364- 200	200	5	16	270	300
0364002506000	364- 250	250	5	16	350	410
0364003006000	364- 300	300	5	18	545	610
0364003506000	364- 350	350	5	18	670	690
0364004006000	364- 400	400	5	20	950	820

MAURERSTEINMEISSEL **STONE CHISELS**

362-...

→
Schlagkopf induktiv vergütet
Striking head inductive hardened

Anwendung *für Steinbearbeitung* *for use on masonry*
 Ausführung *Schäfte flachoval, schwarz lackiert* *flat oval section shanks, black lacquered*
 Material *Chrom-Vanadium 59 CrV 4, Code No. 1.2242* *Chrome-Vanadium 59 CrV 4, Code No. 1.2242*
 Normung **DIN 7254, Form A** **DIN 7254, Form A**

Code	ELORA-Nr. ELORA-No.	L mm	Schneidenbreite mm Width of edge mm	Ø mm	📦	⚖️ g
0362002006000	362- 200	200	26	20 × 12	5	300
0362002506000	362- 250	250	26	20 × 12	5	410
0362003006000	362- 300	300	29	23 × 13	5	610
0362003506000	362- 350	350	29	23 × 13	5	690
0362004006000	362- 400	400	29	23 × 13	5	820

ELEKTRIKERMEISSEL **ELECTRICIANS CHISELS**

365-...

→
Schlagkopf induktiv vergütet
Striking head inductive hardened

Anwendung *für Steinbearbeitung* *for use on masonry*
 Ausführung *Schäfte 4-kantig, schwarz lackiert* *square section shanks, black lacquered*
 Material *Chrom-Vanadium 59 CrV 4, Code No. 1.2242* *Chrome-Vanadium 59 CrV 4, Code No. 1.2242*

Code	ELORA-Nr. ELORA-No.	L mm	Schneidenbreite mm Width of edge mm	Ø mm	📦	⚖️ g
0365020066008	365-200× 6× 8	200	8	6 × 6	5	95
0365020086010	365-200× 8×10	200	10	8 × 8	5	115
0365025086010	365-250× 8×10	250	10	8 × 8	5	135
0365025106015	365-250×10×15	250	12	8 × 8	5	220
0365025126012	365-250×12×12	300	12	8 × 8	5	310

- 01
- 02
- 03
- 04
- 05
- 06
- 07
- 08
- 09
- 10
- 11
- 12
- 13

UNIVERSAL-HANDSCHUTZGRIFF **UNIVERSAL CHISEL GRIP OR HAND GUARD**

283HS



Anwendung für Meißelschäfte flachoval für 20 × 12; 23 × 13; 26 × 13 mm
 Application flat oval for 20 × 12; 23 × 13; 26 × 13 mm
 8-kant für 16; 18; 20 mm octagon for 16; 18; 20 mm
 Material aus schlagfestem Spezialgummi
 Material made from impact resistant rubber

Code	ELORA-Nr. ELORA-No.	L mm			g
0283000000000	283HS	130	6		125

SCHLITZ ODER KAROSSERIEMEISSEL **SLIT OR CAR BODY CHISEL**

361

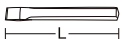

→ Schlagkopf induktiv vergütet
 Striking head inductive hardened

Anwendung für Karosseriearbeiten
 Application for use on car bodies
 Ausführung extra flach, schwarz lackiert
 Type extra flat, black lacquered
 Material Chrom-Vanadium 59 CrV 4, W.-Nr. 1.2242
 Material Chrome-Vanadium 59 CrV 4, Code No. 1.2242

Code	ELORA-Nr. ELORA-No.	L mm	Schneidenbreite mm Width of edge mm	Ø mm			g
0361000000000	361	240	26	26 x 7	5		280

HANDSCHUTZGRIFF FÜR SCHLITZMEISSEL **CHISEL SAFETY GRIP FOR SLIT CHISEL**

361HS

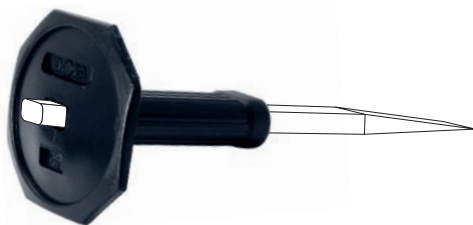

Anwendung für Schlitzmeißel
 Application ELORA-Nr. 361
 Material aus schlagfestem Spezialgummi
 Material made from impact resistant rubber

Code	ELORA-Nr. ELORA-No.	L mm			g
0361000007000	361HS	130	6		94

KÖRNER **CENTRE PUNCHES**

265-...



→ Schlagkopf induktiv vergütet
 Striking head inductive hardened

Ausführung Kegel und Spitzen geschliffen, schwarz lackiert
 Type taper sections and tips ground, black lacquered
 Material Chrom-Molybdän 45 CrMoV 7, W.-Nr. 1.2328
 Material Chrome-Molybdenum 45 CrMoV 7, Code No. 1.2328
 Normung **DIN 7250**
 Standard **DIN 7250**

Code	ELORA-Nr. ELORA-No.	L mm	Spitzen-Ø mm Tip-Ø mm	Ø mm			g
0265001006000	265- 10	120	4	10	10		65
0265001206000	265- 12	120	5	12	10		90
0265001216000	265- 12L	150	5	12	10		120

DURCHTREIBER **TAPER PUNCHES**

264-...



→ Schlagkopf induktiv vergütet
 Striking head inductive hardened

Ausführung Treibkegel und -flächen geschliffen, schwarz lackiert
 Type taper sections and surfaces ground, black lacquered
 Material Chrom-Molybdän 45 CrMoV 7, W.-Nr. 1.2328
 Material Chrome-Molybdenum 45 CrMoV 7, Code No. 1.2328
 Normung **DIN 6458**
 Standard **DIN 6458**

Code	ELORA-Nr. ELORA-No.	L mm	Spitzen-Ø mm Tip-Ø mm	Ø mm			g
0264012106020	264- 120x10x 2	120	2,0	10	10		58
0264012106030	264- 120x10x 3	120	3,0	10	10		62
0264012106040	264- 120x10x 4	120	4,0	10	10		64
0264012106050	264- 120x10x 5	120	5,0	10	10		66
0264012106060	264- 120x10x 6	120	6,0	10	10		66
0264012126020	264- 120x12x 2	120	2,0	12	10		86
0264012126030	264- 120x12x 3	120	3,0	12	10		88
0264012126040	264- 120x12x 4	120	4,0	12	10		90
0264012126050	264- 120x12x 5	120	5,0	12	10		94
0264012126060	264- 120x12x 6	120	6,0	12	10		96
0264012126070	264- 120x12x 7	120	7,0	12	10		96
0264012126080	264- 120x12x 8	120	8,0	12	10		98
0264012126100	264- 120x12x10	120	10,0	12	10		104

SPLINTTREIBER PARALLEL PIN PUNCHES

271-...

→ Schlagkopf induktiv vergütet
Striking head inductive hardened

Ausführung Treibdorne und -flächen taper sections and surfaces
Type geschliffen, schwarz lackiert ground, black lacquered

Material Chrom-Vanadium 58 CrV 4, Chrome-Vanadium 58 CrV 4,
Material W.-Nr. 1.8161 Code No. 1.8161

Normung **DIN 6450** **DIN 6450**
Standard

Code	ELORA-Nr. ELORA-No.	L mm	Treib- spitze Front section L mm	Spitzen-Ø mm Tip-Ø mm	Ø mm	📦	📊 g
0271000206000	271- 2	150	30	2,0	10	10	70
0271000306000	271- 3	150	40	3,0	10	10	66
0271000406000	271- 4	150	50	4,0	10	10	66
0271000506000	271- 5	150	50	5,0	10	10	66
0271000606000	271- 6	150	50	6,0	10	10	70
0271000706000	271- 7	150	50	7,0	12	10	102
0271000806000	271- 8	150	50	8,0	12	10	108
0271000906000	271- 9	150	50	9,0	12	10	112
0271001006000	271-10	150	50	10,0	12	10	100
0271000416000	271- 4L	175	80	4,0	10	10	62
0271000616000	271- 6L	175	80	6,0	10	10	70

MEISSEL-SÄTZE CHISEL AND PUNCH SETS

266K/266KS/266S

266K in Metallkassette
in a metal case

266KS im Kunststoffhalter
in a plastic stand

266S im Holzständer
in a wooden stand

6-tlg./pcs.

Ausführung mit 2 Meißeln, Körner und 2 with 2 chisels, centre and 2 drift
Type Durchtreibern, in Metallkassette, punches in metal case, in plastic
Kunststoffhalter oder Holzständer stand, or in wooden stand

Code	ELORA-Nr. ELORA-No.	Inhalt je 1 Stück Contents 1 piece of each	📦	📊 g
0266500626000	266K	262-125 mm Flachmeißel Flat Cold Chisel	1	890
0266500627000	266KS	262-150 mm Flachmeißel Flat Cold Chisel	1	580
0266500606000	266S	263-125 mm Kreuzmeißel Cross Cut Chisel	1	650
		264-120 × 10 × 4 mm Durchtreiber Taper Punch		
		264-120 × 12 × 4 mm Durchtreiber Taper Punch		
		265-120 × 10 mm Körner Centre Punch		

DURCHTREIBER-SÄTZE TAPER PUNCH SETS

264K/264KS

264K in Metallkassette
in a metal case

264KS im Kunststoffhalter
in a plastic stand

6-tlg./pcs.

Ausführung mit Durchtreiber und Körner, in with drift and center punches, in
Type Metallkassette oder Kunststoffhalter metal case or in plastic stand

Code	ELORA-Nr. ELORA-No.	Inhalt je 1 Stück Contents 1 piece of each	📦	📊 g
0264500606000	264K	264-120 × 10 × 2 mm Durchtreiber Taper Punch	1	780
0264500607000	264KS	264-120 × 10 × 3 mm Durchtreiber Taper Punch	1	780
		264-120 × 10 × 4 mm Durchtreiber Taper Punch		
		264-120 × 10 × 5 mm Durchtreiber Taper Punch		
		264-120 × 10 × 6 mm Durchtreiber Taper Punch		
		265-120 × 10 mm Körner Centre Punch		

SPLINTTREIBER-SÄTZE PARALLEL PIN PUNCH SETS

271K/271KS/271S

271K in Metallkassette
in a metal case

271KS im Kunststoffhalter
in a plastic stand

271S im Holzständer
in a wooden stand

6-tlg./pcs.

Ausführung mit Splinttreibern in Metall- with parallel pin punches in metal
Type kassette, Kunststoffhalter oder case, or in plastic stand, or in
Holzständer wooden stand

Code	ELORA-Nr. ELORA-No.	Inhalt je 1 Stück Contents 1 piece of each	📦	📊 g
0271500616000	271K	271-150 × 2 mm Splinttreiber Parallel Pin Punch	1	815
0271500617000	271KS	271-150 × 3 mm Splinttreiber Parallel Pin Punch	1	540
0271500606000	271S	271-150 × 4 mm Splinttreiber Parallel Pin Punch	1	580
		271-150 × 5 mm Splinttreiber Parallel Pin Punch		
		271-150 × 6 mm Splinttreiber Parallel Pin Punch		
		271-150 × 8 mm Splinttreiber Parallel Pin Punch		

VERKAUFS-STÄNDER **CHISEL AND PUNCH DISPENSER UNIT**
266P

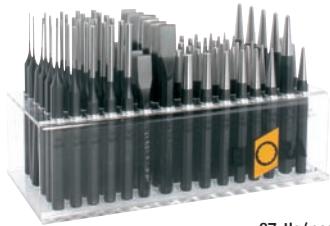

87-tlg./pcs.

Inhalt | Meißel, Körner, Durchtreiber und Splinttreiber | *chisels, taper-, centre- and parallel pin punches*
Ausführung | Kunststoff, Breite: 271mm Höhe: 81mm Tiefe: 130mm | *transparent acrylic sheeting, Width: 271mm Height: 81mm Depth: 130mm*

Code	ELORA-Nr. ELORA-No.	Inhalt Contents	Stk pieces each	📦	📊 kg
0266508706000	266P	Flachmeißel <i>Flat cold chisels</i> ○ 262-125 mm 262-150 mm Durchtreiber <i>Taper punches</i> ○ 264-120 × 10 × 2 mm 264-120 × 10 × 3 mm 264-120 × 10 × 4 mm 264-120 × 10 × 5 mm 264-120 × 10 × 6 mm 264-120 × 10 × 8 mm Körner <i>Centre punches</i> ○ 265-120 × 10 mm 265-150 × 12 mm Splinttreiber <i>Parallel pin punches</i> ○ 271- 2 × 150 mm 271- 3 × 150 mm 271- 4 × 150 mm 271- 5 × 150 mm 271- 6 × 150 mm	5 6 6 6 6 6 5 6 5 6 6 6 6 6	1	7,7
0266508707000	266P	leer <i>empty</i>	1	600	

VERKAUFS-STÄNDER **CHISEL AND PUNCH DISPENSER UNIT**
266HP



60-tlg./pcs.

Inhalt | Meißel und Körner | *chisels and centre punches*
Ausführung | Kunststoff, Breite: 295mm Höhe: 83mm Tiefe: 145mm | *transparent acrylic sheeting, Width: 295mm Height: 83mm Depth: 145mm*

Code	ELORA-Nr. ELORA-No.	Inhalt Contents	Stk pieces each	📦	📊 kg
0266506006000	266HP	Flachmeißel <i>Flat cold chisels</i> ○ 260-125 mm 260-150 mm 260-175 mm 260-200 mm 260-250 mm 260-300 mm Kreuzmeißel <i>Cross cut chisels</i> ○ 261-150 mm 261-200 mm Körner <i>Centre punches</i> ○ 265-120 × 10 mm 265-150 × 12 mm	6 6 6 6 6 6 6 6 6	1	19,8
0266506007000	266HP	leer/empty	500		

KUNSTSTOFFHALTER FÜR HANDSCHLAGWERKZEUGE **PLASTIC HOLDERS FOR HAND STRIKING TOOLS**
267-H...



**NEU!
NEW!**

Anwendung | für flachovale und oktagonale Meißel, Körner, Durch- und Splinttreiber | *for flat oval and octagonal chisels, center-, drift- and pin punches*
Ausführung | schwarze Kunststoff-Hängehalter | *black, plastic holder*
Material | Kunststoff | *plastic*

Code	ELORA-Nr. ELORA-No.	Schaftformen/-größen Shaft forms/-sizes in mm	📦	📊 g
0267000017000	267-H 1	○ 10	10	12
0267000027000	267-H 2	○ 12	10	12
0267000037000	267-H 3	○ 16	10	12
0267000047000	267-H 4	○ 18	10	12
0267000057000	267-H 5	○ 20	10	12
0267000067000	267-H 6	○ 14 x 9	10	12
0267000077000	267-H 7	○ 17 x 11	10	12
0267000087000	267-H 8	○ 20 x 12	10	12
0267000097000	267-H 9	○ 23 x 13	10	12
0267000107000	267-H 10	○ 26 x 13	10	12
0267000117000	267-H 11	○ 26 x 7	10	12

ELORA-QUALITÄT FÜR „DURCHSCHLAGENDEN“ ERFOLG! 



ELORA QUALITY HITS THE NAIL ON THE HEAD!

HENKELLOCHEISEN		WAD PUNCHES			
285-...					
Anwendung Application	zum Ausstanzen von Pappe, Leder, Gummi und anderen weichen Werkstoffen	<i>for a perforation of carton, leather, rubber and other soft materials</i>			
Ausführung Type	robust geschmiedete Formen , lackiert, Pfeifen blank geschliffen, innen leicht konisch zum Entfernen der Ausschnitte	<i>robust forged forms, lacquered, channels polished, internal lightly conical for taking out the cuttings</i>			
Material Material	Vergütungsstahl	<i>high grade tool steel</i>			
Normung Standard	DIN 7200, Form A	<i>DIN 7200, Form A</i>			
Code	ELORA-Nr. ELORA-No.	Ø mm	L mm		 g
0285000026000	285- 2	2	105	12	40
0285000036000	285- 3	3	105	12	40
0285000046000	285- 4	4	105	12	40
0285000056000	285- 5	5	110	12	55
0285000066000	285- 6	6	110	12	60
0285000076000	285- 7	7	120	12	80
0285000086000	285- 8	8	120	12	85
0285000096000	285- 9	9	120	12	90
0285000106000	285-10	10	130	12	120
0285000116000	285-11	11	130	12	120
0285000126000	285-12	12	130	12	120
0285000136000	285-13	13	140	6	155
0285000146000	285-14	14	140	6	155
0285000156000	285-15	15	140	6	160
0285000166000	285-16	16	140	6	170
0285000176000	285-17	17	145	6	205
0285000186000	285-18	18	145	6	210
0285000196000	285-19	19	145	6	210
0285000206000	285-20	20	160	6	290
0285000216000	285-21	21	160	6	290
0285000226000	285-22	22	160	6	300
0285000236000	285-23	23	165	3	325
0285000246000	285-24	24	165	3	340
0285000256000	285-25	25	170	3	355
0285000266000	285-26	26	170	3	360
0285000276000	285-27	27	175	3	450
0285000286000	285-28	28	175	3	460
0285000296000	285-29	29	175	3	460
0285000306000	285-30	30	190	3	560
0285000316000	285-31	31	190	3	560
0285000326000	285-32	32	190	3	560
0285000336000	285-33	33	195	1	640
0285000346000	285-34	34	195	1	650
0285000356000	285-35	35	195	1	660
0285000366000	285-36	36	195	1	660
0285000376000	285-37	37	205	1	750
0285000386000	285-38	38	205	1	780
0285000396000	285-39	39	210	1	800
0285000406000	285-40	40	210	1	810
0285000416000	285-41	41	210	1	820
0285000426000	285-42	42	220	1	980
0285000436000	285-43	43	220	1	980
0285000446000	285-44	44	220	1	980

Code	ELORA-Nr. ELORA-No.	Ø mm	L mm		 g
0285000456000	285-45	45	220	1	1000
0285000466000	285-46	46	220	1	1100
0285000476000	285-47	47	230	1	1160
0285000486000	285-48	48	230	1	1180
0285000496000	285-49	49	230	1	1190
0285000506000	285-50	50	230	1	1200
0285000516000	285-51	51	230	1	1200
0285000526000	285-52	52	245	1	1850
0285000536000	285-53	53	245	1	1850
0285000546000	285-54	54	245	1	1850
0285000556000	285-55	55	245	1	1850
0285000566000	285-56	56	260	1	1850
0285000576000	285-57	57	260	1	1850
0285000586000	285-58	58	260	1	1850
0285000596000	285-59	59	260	1	1850
0285000606000	285-60	60	260	1	1850
0285000616000	285-61	61	260	1	1850
0285000626000	285-62	62	260	1	1850
0285000636000	285-63	63	260	1	1850
0285000646000	285-64	64	260	1	1850
0285000656000	285-65	65	260	1	3650
0285000666000	285-66	66	300	1	3650
0285000676000	285-67	67	300	1	3650
0285000686000	285-68	68	300	1	3650
0285000696000	285-69	69	300	1	3650
0285000706000	285-70	70	300	1	3650

Weitere Größen auf Anfrage lieferbar! *Further sizes are available on request!*

HENKELLOCHEISEN-SÄTZE		WAD PUNCH SETS			
285S8/285S10					
		8+10-tlg./pcs.			
Ausführung Type	in schwarzen Kunststoff-Rolltaschen	<i>in black plastic wallets</i>			
Code	ELORA-Nr. ELORA-No.	Inhalt Ø Contents Ø		 g	
0285500806000	285 S8	3; 6; 8; 10; 12; 16; 20; 25 mm	1	1475	
0285501006000	285 S10	3; 5; 7; 8; 10; 13; 16; 19; 22; 25 mm	1	1775	

ACHTUNG!
Um unnötige Beschädigungen zu vermeiden, ist es empfehlenswert, beim Stanzen von Holz, Pappe, Leder oder etwas vergleichbarem eine Unterlage zu verwenden!

ATTENTION!
Please use a strong backing during the perforation of wood, carton, leather or something similar to avoid unnecessary damages!

01
02
03
04
05
06
07
08
09
10
11
12
13

RUNDLOCHEISEN BELT PUNCHES

286-...

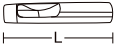

Anwendung Application zum Ausstanzen von Pappe, Leder, Gummi und anderen weichen Werkstoffen *for a perforation of carton, leather, rubber and other soft materials*

Ausführung Type lackiert, Pfeifen blank geschliffen *lacquered, channels polished*

Material Material Vergütungsstahl *high grade tool steel*

Normung Standard **DIN 7200, Form B** *DIN 7200, Form B*

Code	ELORA-Nr. ELORA-No.	Ø mm	L mm		
028600016000	286- 1	1	105	12	20
028600026000	286- 2	2	105	12	20
028600036000	286- 3	3	105	12	25
028600046000	286- 4	4	110	12	35
028600056000	286- 5	5	115	12	40
028600066000	286- 6	6	115	12	45
028600076000	286- 7	7	120	12	60
028600086000	286- 8	8	120	12	75
028600096000	286- 9	9	125	12	100
028600106000	286-10	10	125	12	115
028600116000	286-11	11	125	12	150
028600126000	286-12	12	130	12	180
028600136000	286-13	13	130	6	185
028600146000	286-14	14	135	6	195
028600156000	286-15	15	135	6	200
028600166000	286-16	16	140	6	260
028600176000	286-17	17	140	6	270
028600186000	286-18	18	150	6	320
028600196000	286-19	19	150	6	365
028600206000	286-20	20	155	6	410
028600216000	286-21	21	155	6	440
028600226000	286-22	22	155	6	490
028600236000	286-23	23	155	3	490
028600246000	286-24	24	160	3	550
028600256000	286-25	25	160	3	550

Weitere Größen auf Anfrage lieferbar! *Further sizes are available on request!*

ACHTUNG!

Um unnötige Beschädigungen zu vermeiden, ist es empfehlenswert, beim Stanzen von Holz, Pappe, Leder oder etwas vergleichbarem eine Unterlage zu verwenden!

ATTENTION!

Please use a strong backing during the perforation of wood, carton, leather or something similar to avoid unnecessary damages!

SCHLAGZIFFERN-SÄTZE FIGURE MARKING PUNCH SETS

400Z-...



Anwendung Application zum Einschlagen in Stahl *for marking in steel*

Ausführung Type 9 Ziffern von 0 – 9, in stabilen Kunststoffdosen *set of 9 figures: 0 – 9, in stable plastic storage boxes*

Normung Standard **DIN 1451** *DIN 1451*

Code	ELORA-Nr. ELORA-No.	Schriftgröße mm Size of figures mm	Schaft mm Shank mm		
040000020000	400Z- 2	2	6× 65	1	
040000030000	400Z- 3	3	6× 65	1	
040000040000	400Z- 4	4	7× 65	1	
040000050000	400Z- 5	5	8× 65	1	
040000060000	400Z- 6	6	9× 70	1	
040000070000	400Z- 7	7	10× 75	1	
040000080000	400Z- 8	8	11× 75	1	
040000100000	400Z-10	10	12× 80	1	
040000120000	400Z-12	12	14× 80	1	
040000150000	400Z-15	15	16× 90	1	
040000200000	400Z-20	20	18×100	1	

SCHLAGBUCH-STABENSÄTZE LETTER MARKING PUNCH SETS

400B-...



Anwendung Application zum Einschlagen in Stahl *for marking in steel*

Ausführung Type 27 GROSSBUCHSTABEN von A - Z und „&“, in stabilen Kunststoffdosen *set of 27 BIG LETTERS A - Z and "&", in stable plastic storage boxes*

Normung Standard **DIN 1451** *DIN 1451*

Code	ELORA-Nr. ELORA-No.	Schriftgröße mm Size of figures mm	Schaft mm Shank mm		
040001002000	400B- 2	2	6× 65	1	490
040001003000	400B- 3	3	6× 65	1	495
040001004000	400B- 4	4	7× 65	1	670
040001005000	400B- 5	5	8× 65	1	865
040001006000	400B- 6	6	9× 70	1	1180
040001007000	400B- 7	7	10× 75	1	1560
040001008000	400B- 8	8	11× 75	1	1895
040001010000	400B-10	10	12× 80	1	2440
040001012000	400B-12	12	14× 80	1	4500
040001015000	400B-15	15	16× 90	1	4700
040001020000	400B-20	20	18×100	1	6590

QUATROLIT®-RUND-AHLE QUATROLIT®-ROUND AWL

745



Ausführung Klinge verchromt mit **schlagfestem QUATROLIT®** 2-Komponenten Heft
 Type blade chrome plated with **impact resistant QUATROLIT®** 2-Component handle

Material Spezialstahl
 Material special tool steel

Code	ELORA-Nr. ELORA-No.	mm		
0745000001000	745	100 x Ø 6	6	75

QUATROLIT®-VIERKANT-AHLE QUATROLIT®-SQUARE AWL

746



Ausführung 4-kant-Klinge verchromt mit **schlagfestem QUATROLIT®** 2-Komponenten Heft
 Type square-blade chrome plated with **impact resistant QUATROLIT®** 2-Component handle

Material Spezialstahl
 Material special tool steel

Code	ELORA-Nr. ELORA-No.	mm		
0746000001000	746	100 x Ø 6	6	75

SCHRAUBSTÖCKE BENCH VICES
UND ZUBEHÖR AND ACCESSORIES

PARALLEL-SCHRAUBSTÖCKE PARALLEL BENCH VICES

1495-...



Ausstattung große Ambosse, **extra große Spannweiten**, nachstellbare Führungen
 Features large anvils, **extra large openings**, adjustable guides

Ausführung **im Gesenk geschmiedet**, gehärtet, gefräste Spannbacken, schwarz lackiert
 Type **drop forged**, hardened, milled clamping jaws, black lacquered

Material Vergütungsstahl C 43
 Material high grade tool steel C 43

Code	ELORA-Nr. ELORA-No.	Spann- und Backenbreite Width of jaws mm	Spanntiefe Opening mm	Amboss Anvil mm		
1495001154000	1495- 115	115	140	45 x 63	1	7,8
1495001354000	1495- 135	135	170	57 x 75	1	14,0
1495001504000	1495- 150	150	190	65 x 80	1	18,5

DREHTELLER FÜR SCHRAUBSTÖCKE SWIVEL BASE FOR BENCH VICES

1495D-...

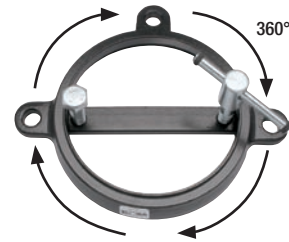

Anwendung zu verwenden mit Parallel-Schraubstöcken ELORA-Nr. 1495
 Application for use with parallel bench vices ELORA-No. 1495

Ausführung **Drehbereich 360° stufenlos**, schwarz lackiert
 Type **turning vice 360° stepless**, black lacquered

Code	ELORA-Nr. ELORA-No.	für Schraubstock ELORA-Nr. for bench vice ELORA-No.	Lochkreis-Ø mm		
1495011154000	1495D- 115	1495-115	165	1	580
1495011354000	1495D- 135	1495-135	195	1	1080
1495011504000	1495D- 150	1495-150	225	1	1400

GASDRUCKLIFT FÜR SCHRAUBSTÖCKE GAS PRESSURE ELEVATOR FOR BENCH VICES

1495L-135



Anwendung für **komfortables Heben und Senken schwerer Schraubstöcke und Werkstücke**, zu verwenden mit Parallel-Schraubstock ELORA-Nr. 1495-135
 Application for **comfortable height adjusting of heavy bench vices or/and workpieces**, for use with parallel bench vice ELORA-No. 1495-135

Ausführung **Hubbereich: bis 240 mm stufenlos**, **Drehbereich: 360° stufenlos**, schwarz lackiert
 Type **Height range: up to 240 mm stepless**, **turning vice 360° stepless**, black lacquered

Ausstattung gasdruckunterstützte Höhenverstellung
 Features Gas pressure elevating mechanism

Code	ELORA-Nr. ELORA-No.	für Schraubstock ELORA-Nr. for bench vice ELORA-No.		
1495021354000	1495L- 135	1495-135	1	9,15

PARALLEL-SCHRAUBSTÖCKE

PARALLEL BENCH VICES

1500-...



Ausstattung / Features: große Ambosse, Spanabführungsritzen in der Führungsschiene
Ausführung / Type: im Gesenk geschmiedet (Ganzstahl), mit gehärteten Stahlbacken

PARALLEL BENCH VICES: large anvils, chip removal grooves
 die forged (all steel) hardened jaws

Code	ELORA-Nr. / ELORA-No.	Spann- und Backenbreite / Width of jaws mm	Spanntiefe / Opening mm	Amboss / Anvil mm		kg
1500000014000	1500- 1	75	45	70x45	1	2,7
1500000024000	1500- 2	100	53	88x59	1	5,4
1500000034000	1500- 3	125	72	116x80	1	10,5
1500000044000	1500- 4	150	90	132x90	1	15,0
1500000054000	1500- 5	175	90	132x90	1	15,5

SCHONBACKEN FÜR SCHRAUBSTÖCKE

JAW CAPS FOR BENCH VICES

1500A-.../1500K-...



Anwendung / Application: passend für alle Schraubstöcke / suitable for all bench vices

Ausstattung / Features: mit Prisma und Magnetstreifen für sicheren Halt an der Backe / with prism and magnetic strips for safe fixing on jaws

Material / Material: A: Aluminium-Legierung, K: Kunststoff / A: alloy, K: plastic

Code	ELORA-Nr. / ELORA-No.	mm		g
1500011004000	1500A-100	100	6	72
1500011254000	1500A-125	125	6	90
1500011504000	1500A-150	150	6	110
1500020804000	1500K- 80	80	6	26
1500021004000	1500K-100	100	6	34
1500021254000	1500K-125	125	6	40
1500021504000	1500K-150	150	6	48

